

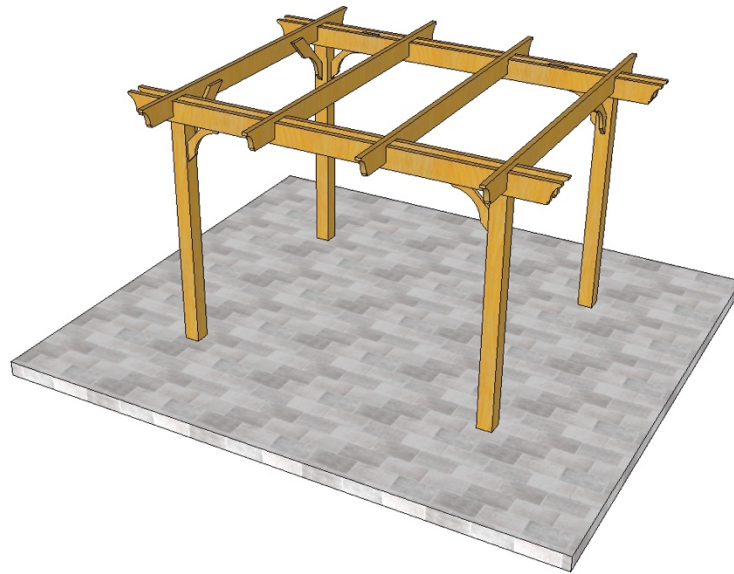

Assembly Instructions Melbourne Pergola Kit



Thank you for purchasing a do-it-yourself pergola kit from Pergola Depot. We appreciate your business, and we are here to help you in any way possible. It will help to read these instructions entirely before beginning. Take your time, follow these instructions, and call us if you need help. You can do this!

If you are installing on a concrete foundation, we recommend you use galvanized steel post bases on each post secured with concrete anchors. For our pressure treated pine kits, we recommend you also install one Tapcon concrete screw in each post base to prevent twisting of the post while drying. The post bases, anchors and Tapcons are included with your kit if purchased with the option to be installed "on a concrete slab or footer" and can be purchased as accessories from us or from your local hardware store. There are instructions on how to install them in this document, and we have a video on the [Installation Information](#) page on our website under the *Resources>Tips* menu.

If you are installing your pergola on top of new footings, allow the concrete to dry before completing the rest of the pergola installation. This may require that you dig the holes and pour the footings one weekend and then assemble the kit the next. Additional instructions are provided below.

Note: If installing a pressure treated pine kit, do not paint or stain until the wood is dry.

Check out the Resources>Tips tab on our website and don't hesitate to contact us if you have questions or need some extra help.

Call: 1-877-563-0002

Email: info@pergoladepot.com

Tools and Supplies Needed

- Helper (we recommend at least 2, especially for larger kits)
- Tape measure, hammer, level
- Ladder (tall enough to work the top of your pergola during assembly)
- Screw gun (a star drive bit is supplied with kit)
- 3/4" Wrench
- For new footings: post hole digger, dry concrete mix, gravel, trowel, shovel and mixing bin or wheel barrow
- For installing rebar into post (if posts going into new concrete foundations): drill, 5/8" drill bit
- For all kits using post bases on concrete: drill; 5/8" masonry drill bit; and 15/16" wrench
- For Pressure Treated Pine kits using post bases on concrete: you will also need a 5/32" masonry drill bit, and a #2 Philips bit or #2 Philips screw driver

Kit Components

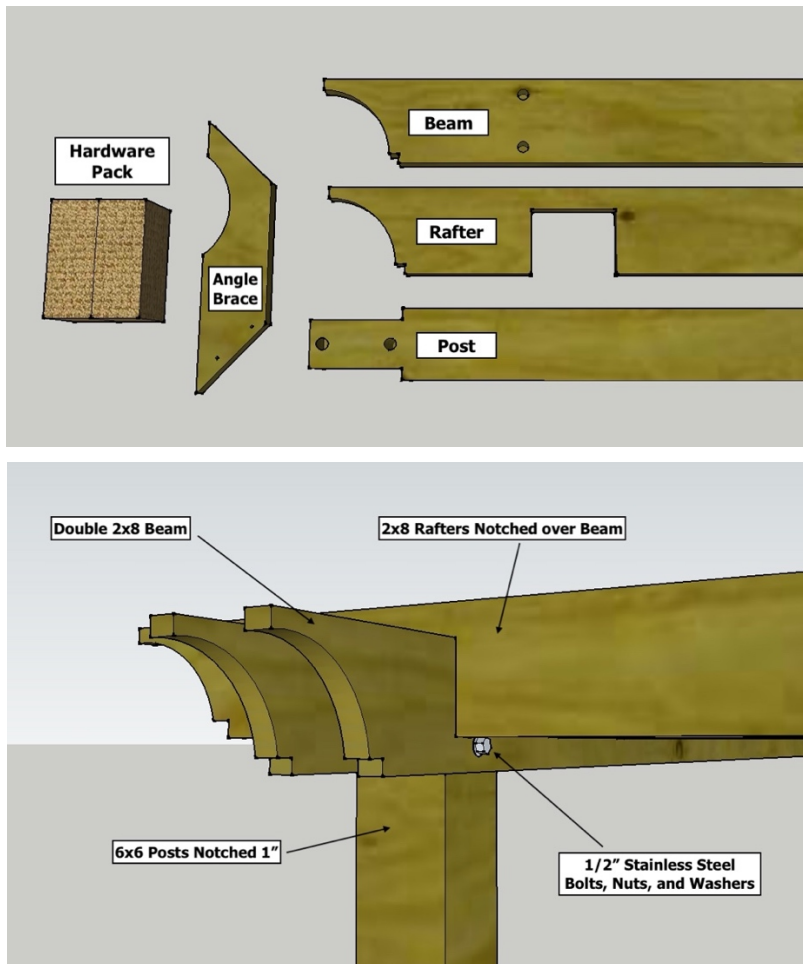

- 2x8 Beams (4 for standard size kits)
- 2x8 Notched Rafters (# depends upon kit size)
- 6x6 Notched Posts (4 for standard size kits)
- 2x6 Angle Braces (8 for standard size kits)
- Hardware Pack - 3" screws, 6" screws, 8" bolts nuts and washers, rebar for post install (if installing in or on new concrete foundation), star drive bit (#s depend upon kit size)
- Optional: post base trim; post base mounting hardware and Tapcons (for pine kits); concrete footing form tubes

Reference the packing list that was provided with your shipment confirmation for a complete list of kit components, including the number of each type of lumber and hardware pack components.

Installation Steps

- **Step 1** - If not already done, remove the crating material from the outside of the kit.
- **Step 2** - Lay all parts next to where you will be installing the pergola.
- **Step 3** - Place all four beams on the ground (with the x's facing up) exactly where you would like the pergola to stand, like so:

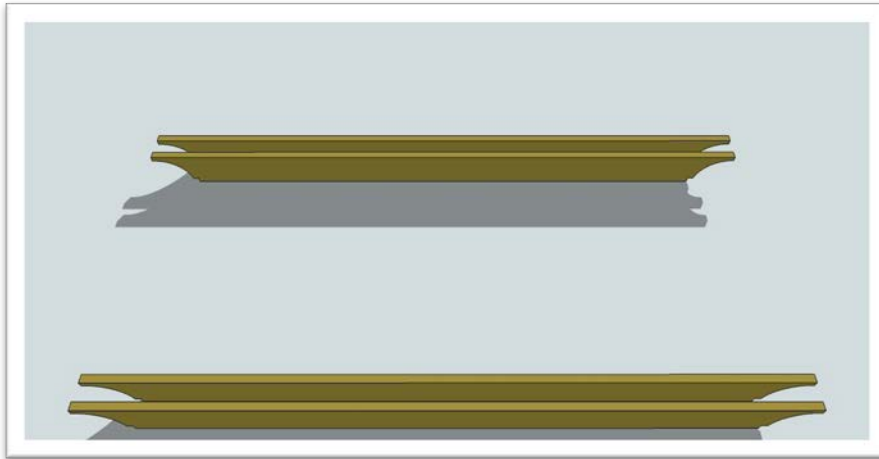

- **Step 4** - Slide two rafters down onto the two outermost X marks on the beams and using the 6" screws, temporarily screw each rafter through the predrilled holes into the beams. Screw them in just enough to hold the rafter in place. You may have to move the back beam around a little to get it into place. Make sure you have the rafter on top of the same mark on both beams. The X marks look like this: IXI

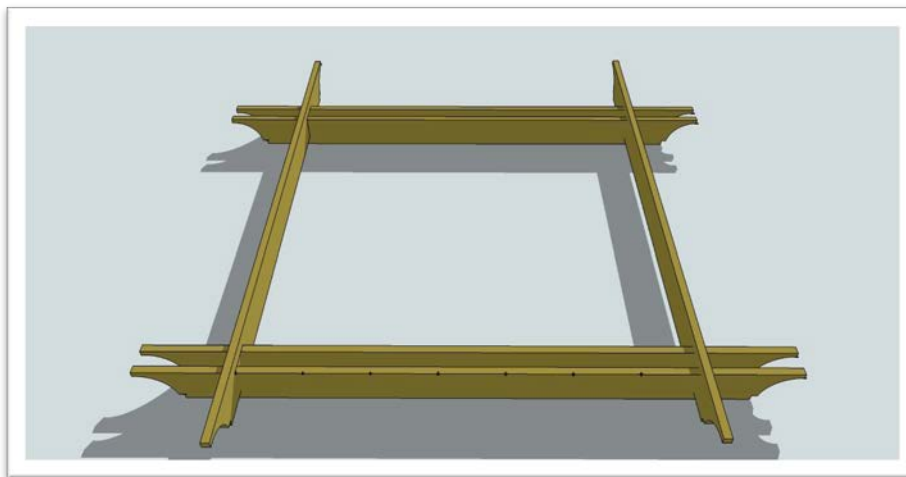

- **Step 5** - Step back and look to see how square everything looks. Take a tape measure and hook it on the outside tip of the rafters and pull the tape to the opposite corner. Write down the measurement. Then hook it on the other corner and pull to the opposite corner like this:

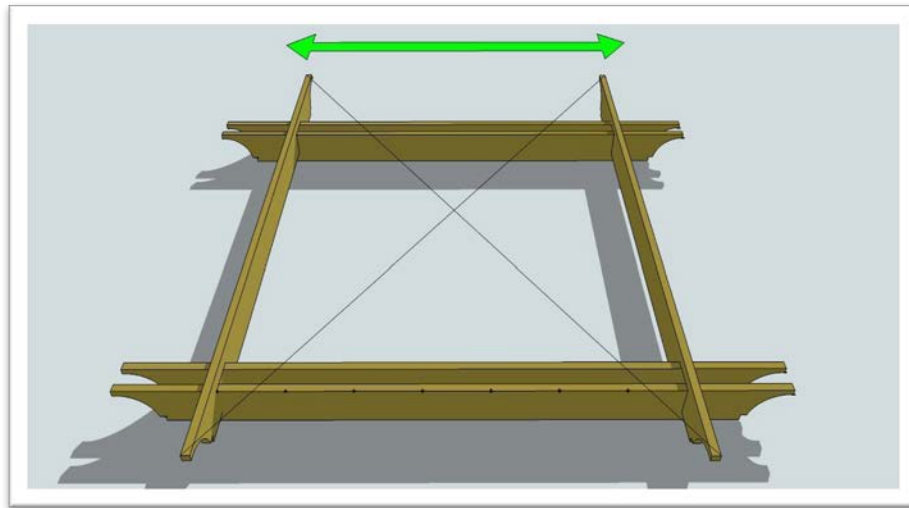

Move the back beam from side to side until you have the same measurement both ways. When you have the same measurement, it is perfectly square. **Hint:** This is easier if you and your helper both have a tape measure and pull them across at the same time.

- **Step 6** - Now you can see where you should dig your holes for each post. (Or mount your post bases if you're on concrete.) Look at the top of the beam just inside the first rafter where it says post. If you are on concrete, make a mark on the concrete directly in the center of the lines where it says post on all four corners. If you are on grass or dirt, stick the flags that are provided with the kit into the ground on all corners where it says post.
- **Step 7** - Unscrew and remove the rafters from the beams and move everything out of the way. Now you should be left with four marks where your holes or post bases will go.
- **Step 8** - Dig the post holes with the center of your hole at your mark, 2 to 4 feet deep (depending on the depth desired - see our website under [Resources>Tips>Post Information](#)) and 24" in diameter or install your post bases directly over top of all 4 of your markers. If you are pouring new footings on which to mount your posts, proceed to the next step and come back to this step when you are ready to mount the post bases.

Post Base Installation:

If installing using post bases on top of an existing concrete foundation or previously poured footings, place the bases on the concrete in the exact position where they will be installed. **Hint:** The measurements between the center of each post base should be the same as the center post to post measurement for your size pergola, which is 3'6" less than the overall size for each dimension. For example, a 10x12 pergola has a center post to post measurement of 6'6" x 8'6". Find the center of the hole on the bottom of the

base, mark that point, and drill into the concrete with a 5/8" concrete drill bit at least 4" deep. Clear excess debris from the hole. Place the washer and nut on the concrete anchor, place the flared end into the hole in the concrete, and hammer it down until it is against the post base, but do not tighten. Repeat for each base. Before tightening the anchor to the post base, make sure that each base is square to the outside edge of your pergola footprint. Lay one of the beams or rafters (depending upon length needed) on the ground directly outside two of the post bases, then rotate the post bases until the outside edges of each base are touching and square with the board. Repeat this for the other bases. Once square, tighten each anchor with a 3/4" wrench until snug to the base.

If installing a pressure treated pine kit using post bases, we recommend you install one Tapcon screw for each base through one of the holes in the post base that surround the first anchor. Using a 5/32" concrete bit, drill the Tapcon screw hole to at least 2" deep. Once the hole is drilled, clear excess debris from the hole, and slowly screw the Tapcon through the post base using a #2 Philips head screw bit or screw driver until snug to the base. Repeat for each base.

- **Step 9** - Pour in gravel to fill the first 4" of each post hole. Continue with the rest of this step if you are installing on top of new concrete footings and have not already poured your footings. Check out the information we have available on our website under [*Resources>Tips>Post Information*](#), and consider using concrete footing form tubes, which you can purchase at your local hardware store. Mix the concrete according to the directions for the concrete you purchased and fill the hole to about 2/3 of the way to ground level. Use a shovel or piece of rebar to eliminate air bubbles. Insert one piece of 18" rebar supplied with your kit into the concrete so that it sits diagonally from the bottom of one side of the hole toward the top of the other side. Pour in more concrete to cover the rebar and until the concrete is level with the ground, or to the desired height to ensure that the top of each footing will be level with each other. If the ground surface is not level, you can use footing form tubes to create a level surface across the top of each footing using a line level. Work the top portion of concrete to eliminate bubbles and smooth the top with a trowel or shovel. Repeat for each footing. Allow to dry completely, which will depend upon the concrete used and weather conditions. Once dry, go back to the previous step for instructions on installing the post bases.
- **Step 10** - For posts that are being installed into concrete footings, we recommend you install a piece of 10" rebar, supplied with the kit, into the bottom of each post. Locate and mark a spot that is approximately 10" below ground level. Using a 5/8" drill bit, drill a hole through the post at the desired mark on each post. Note that the rebar will be inserted in a later step.

- **Step 11** - Lay the four posts on the ground with the bottoms at the edge of each hole, with the tops facing away from each other, like this:

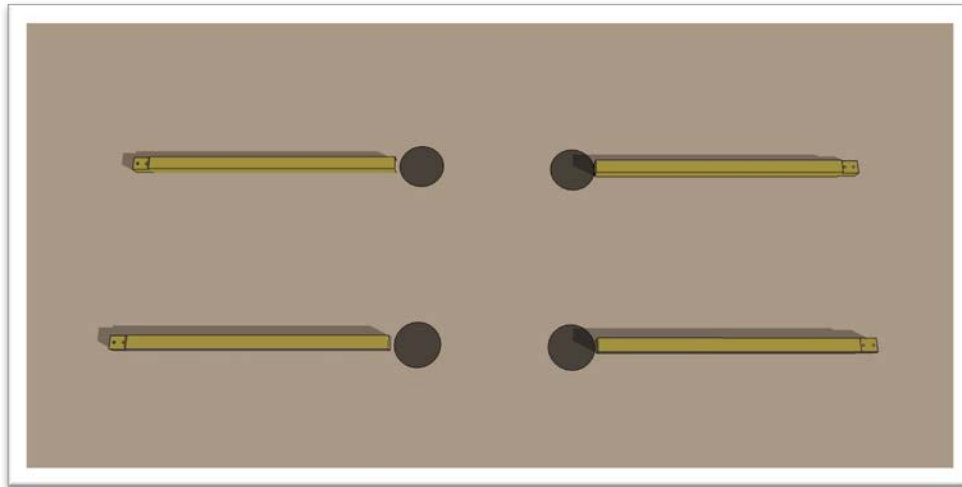

- **Step 12** - If installing post base trim, slide trim over the bottom of each post and up the post so it will be out of the way for the next couple steps. Then insert the rebar through the hole at the bottom of each post. Use a hammer to move the rebar into place through the post until you have approximately equal lengths of rebar on either side of the post.
- **Step 13** - Lay one beam down on the ground near the top of the posts. Slide the posts up and onto the beam between the lines on the beam where it says post.
- **Step 14** - Set the other beam on top sandwiching the post in between the two beams.
- **Step 15** - Place 1 washer on each ½" bolt. Lift the beam assembly enough to fit the bolts between the ground and the beam and insert the bolts into the holes from the bottom. **Hint:** You may want to use a block of wood to place on the ground under the bolt, so you can push the beam down to get the bolt to come up through the hole. Place a washer and nut on each of the bolts and make them snug but do not tighten them down yet. Now you should have this:

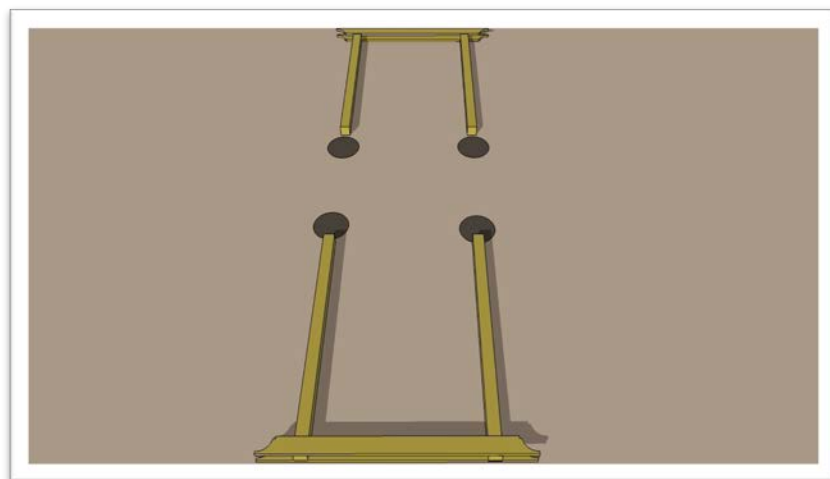

- **Step 16** - With one person on each side, tilt the assembly up and drop the posts into the postholes, or into the post bases if on concrete. Have your helper(s) hold the assembly plumb. (Note: for some of the larger size pergolas this step may require more help.) Refill the holes around the posts with dry concrete. **Do not water in the concrete yet.** Check for level across the top of the beam and on the sides of the posts. **Hint:** To make level, a common solution is to adjust the amount of concrete under the posts by lifting-up the low post and allowing dry concrete to fill in underneath, or if installing on top of a footer or existing slab you may need to use a shim under one or more of the posts.

If you are installing the pergola on concrete with post bases, you will need to have your helper continue to hold the assembly or prop the assembly up so that it does not fall. Once you have the bottom of the posts in the post bases, using the 1 1/2" galvanized nails supplied with your post bases, secure the posts to the bases with one nail on each side of the bases to hold them in place until the rafters are installed.

Repeat for the other beam and post assembly.

- **Step 17** - Move your stepladder in between the two sides. Take one of the rafters and slide it onto the outermost X marks on the beams just like you did on the ground. Then secure the rafter to the beams using 3" screws provided with your kit through the predrilled holes in the rafter onto the top of the beams. Now move to the opposite side and secure another rafter into position on the outermost X marks. Now your helper should be able to let go of the assembly. Check for level and plumb on the posts, beams, and rafters. **Hint:** A common solution is to adjust the amount of concrete under the posts until level, or if installing on top of a footer or existing slab you may need to use a shim under one or more of the posts.
- **Step 18** - Install all of the remaining rafters on the remaining X marks and secure them to the beam with 6" screws through the predrilled holes. If on concrete, now is the time to finish securing the posts to the bases using the galvanized nails supplied with your kit.
- **Step 19** - Check the whole pergola assembly and tighten down any loose nuts and screws.
- **Step 20** - Install the Angle Braces. Four of the braces will go in between the beams and the other four will attach to the inside edge of the outside rafters - like shown in the picture below. To install the first four, slide the corner braces, with the long side towards the top, in between the two pieces of wood that make up the beam until flush with the top of the beam, then push the bottom side against the post. Make sure the angles are flush to the post and to the top of the beam. Screw in two 3" screws through the angle brace into the post through the predrilled holes, then screw the top through the face of one of the beams into the angle with four (4) 3" screws. (Note: there are no predrilled holes in the face of the beam, and you can secure the angle to either the inside or

outside beam.) Repeat for three more angles at each corner of the pergola assembly. For the next four, place the angle against the post with the long side up against the inside of the first rafter. Screw into the post through the predrilled holes at the bottom end that is against the post. Screw four (4) 3" screws through the top of the angle and into the rafter board. Repeat for the other three angles.

This is what they should look like when installed correctly:



- **Step 21** - Water in the concrete around the posts if applicable. Mix the concrete with a shovel following the directions for the concrete you purchased and eliminating air bubbles. Be sure not to move the unit around while the concrete is curing (about 24 hours depending upon concrete used and weather conditions).

Note: If installing a pressure treated pine kit, do not paint or stain until the wood is dry.

You're Done!

Thanks again for your business. We appreciate our customers and their feedback on ways to improve our products. So, after you've completed putting your kit together, sit down, have a cold drink, and drop us a line [via email](mailto:info@pergoladepot.com) to tell us what you think about our products. Any feedback on how we can make our kits easier to install will be very helpful. Pictures are always welcome!

Built with pride in the U.S.A!



Pergola Depot

Call: 1-877-563-0002

Email: info@pergoladepot.com

www.pergoladepot.com